

Automation Solutions for Hydrogen



Leveraging hard and soft skills to meet customer goals

For both hydrogen production and utilization, Comau supports customers in their manufacturing journey. Whatever the product, electrolyzers or fuel cells, and the technology, PEM* or alkaline, Comau works alongside its customers to offer automation solutions for stacking, testing and BoP**, and for components production.

*Proton Exchange Membrane **Balance of Plant



We meet emerging needs of the Hydrogen market

Consultancy: manufacturing concept & simultaneous engineering, DFMEA***, business case support

Validation: in-house lab testing, pilot development

Turnkey supply: scalable and seamless solutions

Digitalization: traceability, quality inspection, line monitoring and simulation

Training & Support: robotics supervision and management, technical training and after sales services

***Design Failure Mode and Effects Analysis

Simultaneous Engineering: 9 Steps to Reshape the Production Process

Experience the power of Simultaneous Engineering, a transformative nine-step process designed to streamline automation projects. From a thorough product and process analysis to the final stages of budgeting and planning, our approach ensures efficient project reshaping, ergonomic and quality analysis, concept layout, station design, control layout, simulation, and validation. With Simultaneous Engineering, we bring your automation vision to life with precision and expertise.

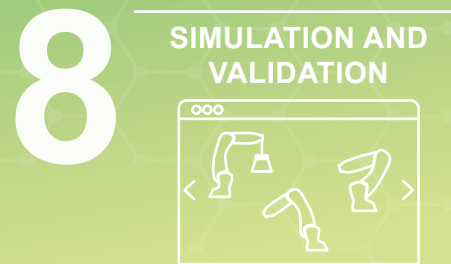
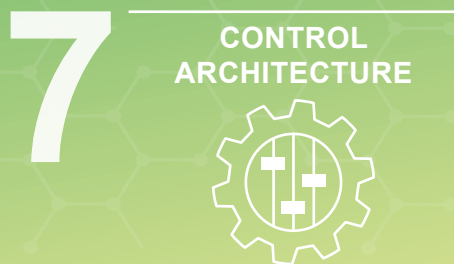
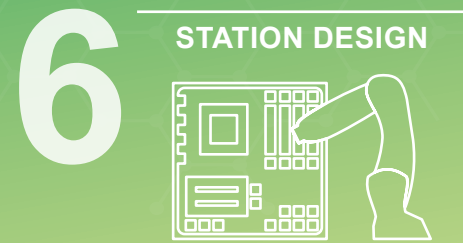
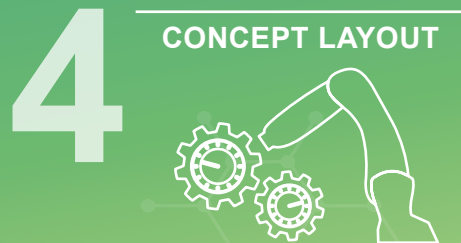
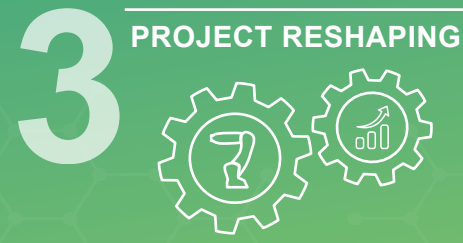

Manufacturing process: where Comau leverages the full potential of automation

Comau's advanced automation solutions expertly handle the critical operations of **fuel cells and electrolyzers** manufacturing.

Separating and cutting technologies ensure precision and consistency while state-of-the-art systems join components, guaranteeing robust and efficient assemblies.

Every unit undergoes rigorous leak testing, validating its integrity and performance, further underscoring our commitment to delivering unparalleled quality and reliability.

A complete family of robots, and advanced gripping and vision systems enable the effective automation of stack and system production.

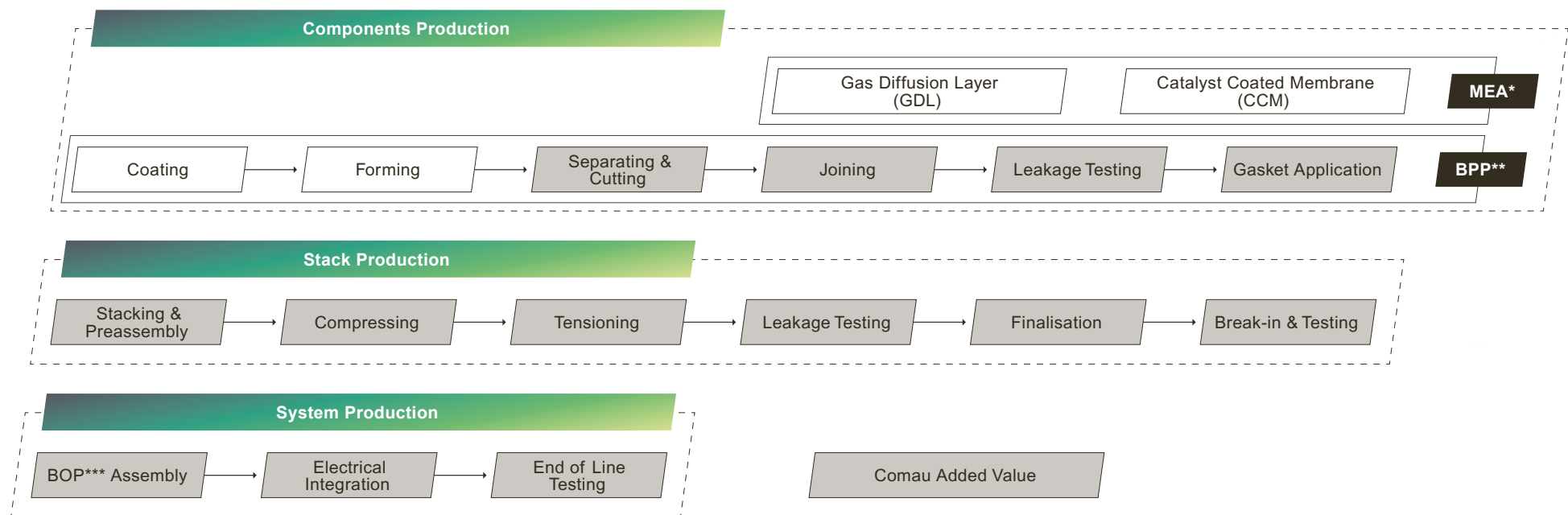

*MEA: Membrane Electrode Assembly

**BPP: Bipolar Plate

***BOP: Balance of Plant

Standard Automation Cells

Comau offers standard pre-configured automation cells to speed up the design and installation time of your automation lines.

Main Advantages:

- Fast set-up with zero engineering design hours
- Workflow optimization with standard robotic setups
- Fully modular and standard assembly cells
- Streamlined digitization
- Ramp-up production in the fastest and most cost-effective way
- Ensure safety and quality control with part repetition and reliability

Arc Welding

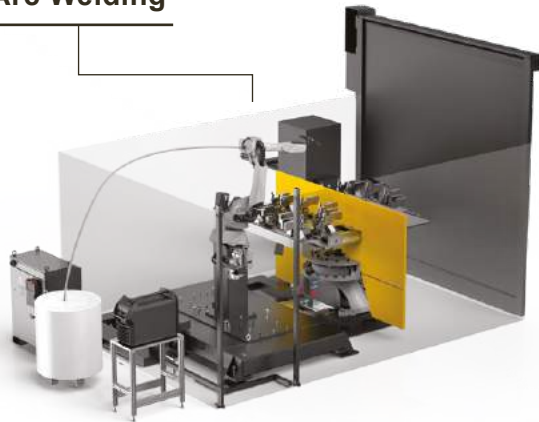

Spot Welding

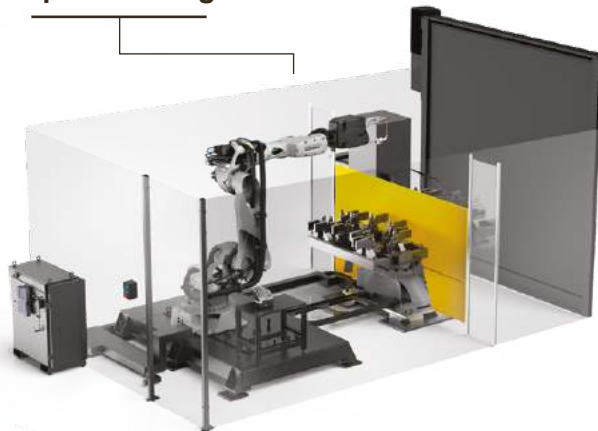

Laser Technology



Comau automation platforms are designed with flexibility in mind. Recognizing the diverse requirements of the industry, our systems accommodate third-party testing machines and are fully compatible with testing solutions from external providers. This adaptability not only ensures a seamless production line but also allows customers the freedom to utilize specialized equipment that is best suited to their specific needs, all while maintaining a cohesive and efficient manufacturing process.

FUEL CELLS Stack Production

When it comes to increasing production volumes while lowering the cost of fuel cell and electrolyzer manufacturing, Comau is your automation partner of choice.

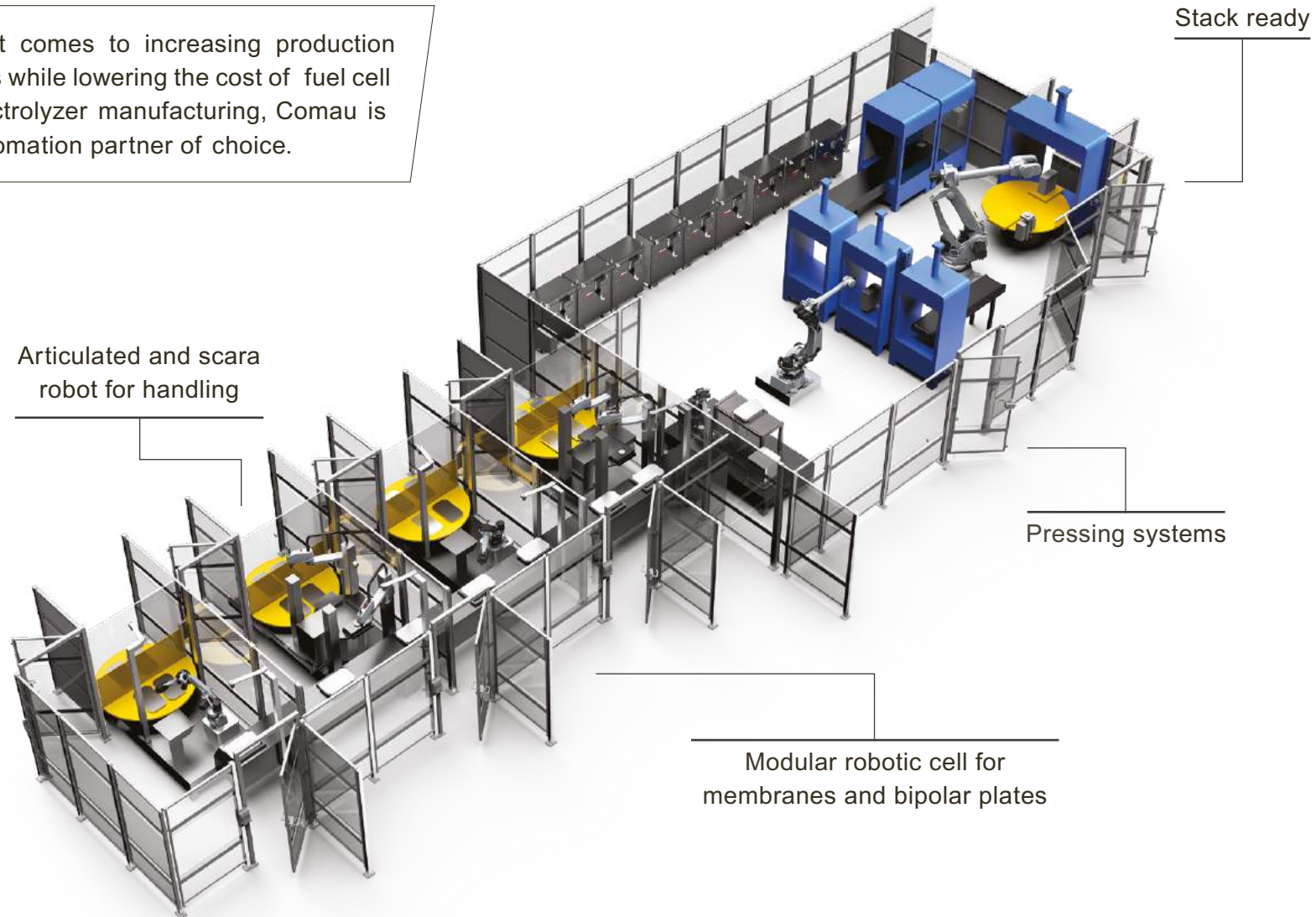

ELECTROLYZERS

Stack Production

From simultaneous engineering to robotics, specialized grippers and vision systems, Comau combines field-proven expertise with enabling technologies to automate and scale-up fuel cell and electrolyzer manufacturing.

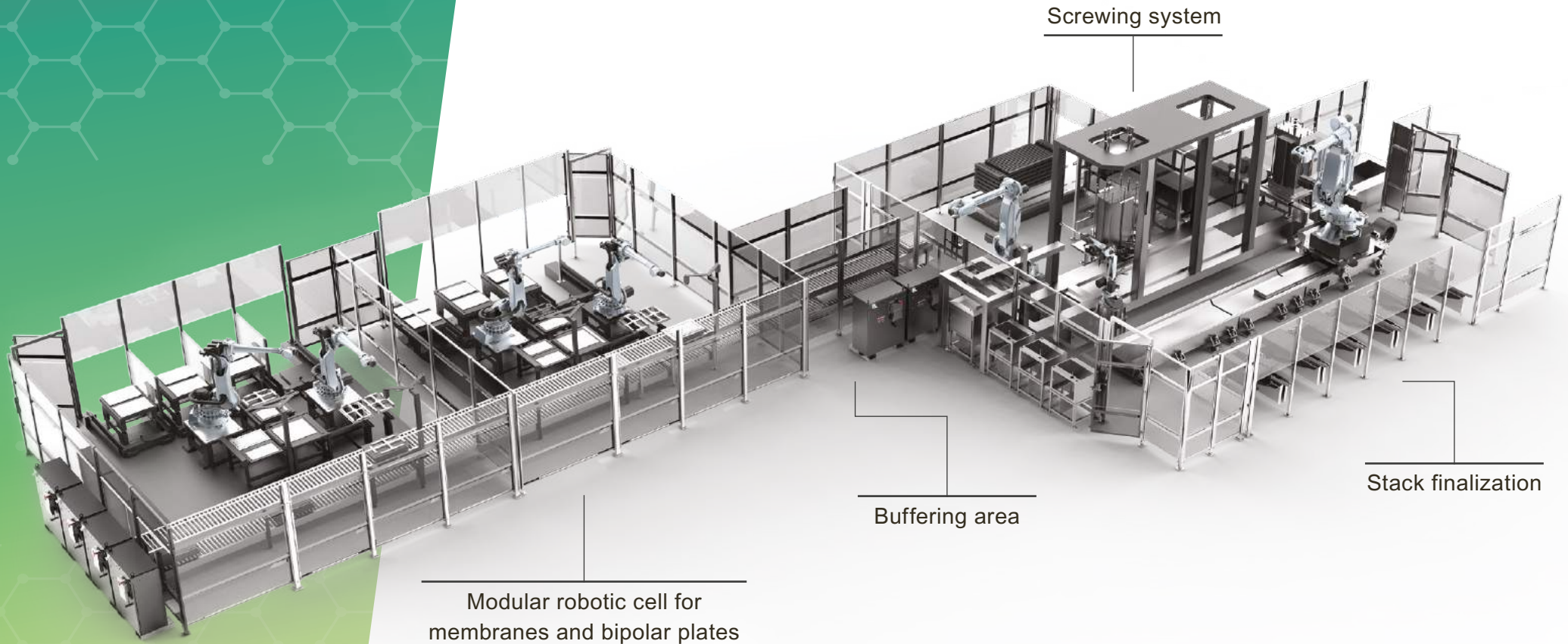



comau.com

Follow us



The contents of this brochure are supplied for general information only. Comau S.p.A. reserves the right to alter specifications at any time without notice for technical or commercial reasons. The illustration does not necessarily show the products in their standard version. Edition - 11/23 - Turin.

Made in Comau